

PRODUCT SPECIFICATIONS

Locking Hose Bib. Overall dimensions are 7-5/16" x 5-3/16" x 10".

Special Features:	316 Stainless, Heavy Duty Vandal Resistant
Mounting Type:	Floor Mount/Freestanding
Finish:	Beige (BGE), Black (BK), Blue (BLU), Brown (BRN), Evergreen (EVG), Gray (GRY), Orange (ORN), Purple (PUR), Red (RED), Terracotta (TER), White (WHT), Yellow (YLW)
Dimensions:	7-5/16" x 5-3/16" x 10"
Shipping Weight:	13 lbs.

Special Note: For use with outdoor tubular fountains and bottle fillers

- Outdoor tubular pedestal fountain ideal for parks and recreational areas.
- Powder-coated exterior over a corrosion-resistant primary coating to provide protection from the elements.
- For use with outdoor tubular fountains and bottle fillers.



A Century of Tradition and Quality.

For more than 100 years, Elkay has been making innovative products and providing exceptional customer care. We take pride in offering plumbing products that make life easier, inspire change and leave the world a better place.



Product Compliance: Buy American Act

[Installation Instructions \(PDF\) - 100004248](#)

PART: _____ QTY: _____

PROJECT: _____

CONTACT: _____

DATE: _____

NOTES: _____

APPROVAL: _____

In keeping with our policy of continuing product improvement, Elkay reserves the right to change product specifications without notice. Please visit elkay.com for the most current version of Elkay product specification sheets. This specification describes an Elkay product with design, quality, and functional benefits to the user. When making a comparison of other producers' offerings, be certain these features are not overlooked.

Parts List		
Item No.	Part No.	Description
1	75624C	Fitting - Hose Vacuum Breaker
2	75619C	Faucet - 1/2" NPT
3	70977C	Nut - Lock 1/2" Conduit
4	70972C	Elbow - 90° x 1/2" MPT
5	75623C	Fitting - Tee 1/2" x 1/2" x 3/8"
6	66555C	Tube - 1/2" O.D. x 36.00" Lg.
7	66475C	Tube - 3/8" O.D. Tee to Strainer
8	66641C	Tube - 1/2" O.D. x 4.38" Lg.
9	45838C*	Door - locking Hose Bib
10	75535C	Screw - 1/4-20 x 3/4" Torx
11	45837C*	Panel - Locking Hose Bib
not shown	75521C	Bit - Pinned Torx T-27 (NS)

*Choose color option from page 1 to complete your item number, add as suffix. Example: 45836C-**EVG**, 45837C-**EVG**, or 45838C-**EVG**

INSTALLATION INSTRUCTIONS

1. Shut off water supply to fountain.
2. Determine location for installation of **Hose Bib Accessory**. Remove existing access cover plate. (This accessory is designed to replace the existing access cover.)
3. Disconnect the **fountain water line** from the **main water supply**. Connect Tube (Item 8) to existing fountain strainer as shown below.
4. Connect Tee (Item 6) to Tube (Item 8). Connect main water supply to Tee using 1/2" Copper Tube (Item 9). **DO NOT TURN MAIN WATER SUPPLY ON AT THIS TIME!**
5. Connect Hose Bib Accessory water line to the Tee and to the Elbow (Item 5) on the Access Panel (Item 3) using 1/2" Copper Tube (Item 7) as shown below, maintain loop in coil to facilitate installation and removal of Access Panel.
6. Turn on main water supply. Check for leaks. If there are leaks, turn off main water supply and correct the water leaks as required. After insuring that all connections are leak free, leave main water supply on and replace any panels that may have been removed in the installation process.
7. Assemble Hose Bib Accessory to the main fountain body.

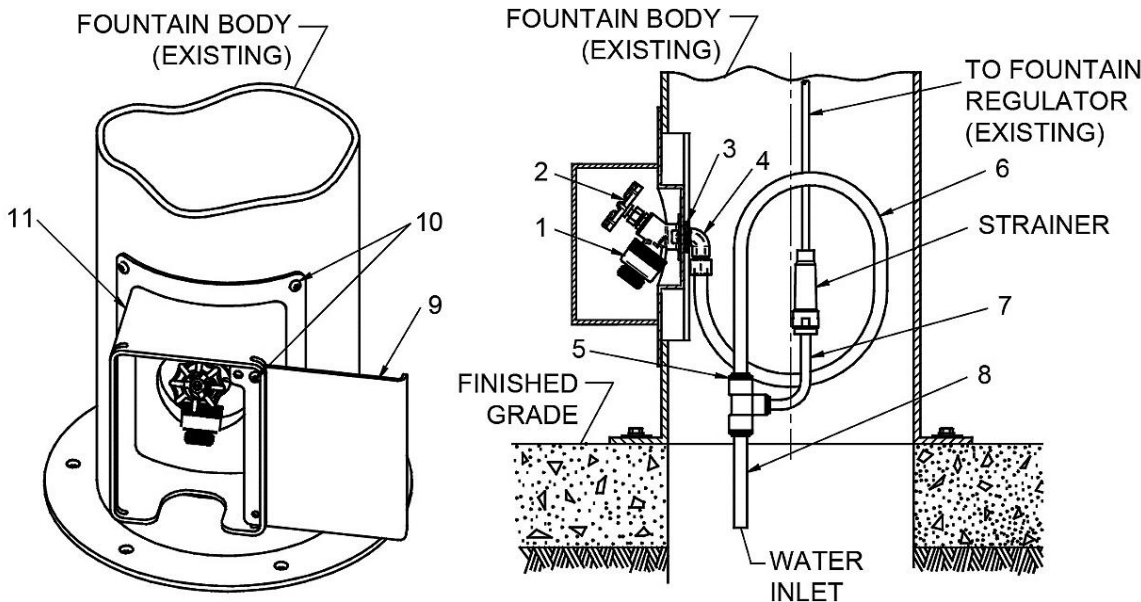
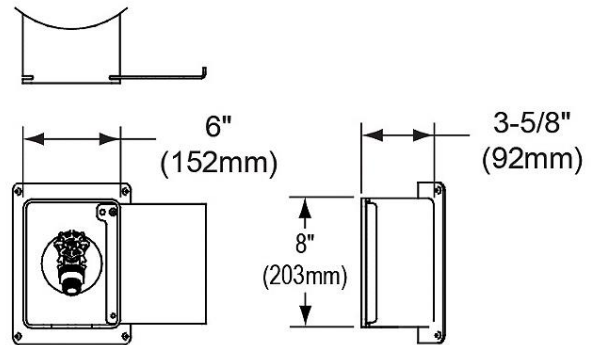

In keeping with our policy of continuing product improvement, Elkay reserves the right to change product specifications without notice. Please visit elkay.com for the most current version of Elkay product specification sheets. This specification describes an Elkay product with design, quality, and functional benefits to the user. When making a comparison of other producers' offerings, be certain these features are not overlooked.