



- Model 3A05 — Recessed **Bradex**[®] (Recesses 3¹³/₁₆" ; projects 4⁷/₈")
- Model 3A05-10 — Semi-Recessed (recesses 2" ; projects 6¹¹/₁₆")
- Model 3A05-11 — Surface-Mounted (projects 8¹¹/₁₆")

Diplomat Series

Product Materials

CABINET: 0.030-inch/22-ga. (0.76 mm) stainless steel with exposed surfaces in architectural satin finish. Welded construction with seamless corners and burr-free edges.

FLANGE: 0.030-inch/22-ga. (0.76 mm) stainless steel with exposed surfaces in architectural satin finish. One-piece seamless construction, 1" wide with 1/4" return.

WASTE CONTAINER: 0.036-inch/20-ga. (.92mm) stainless steel with exposed surfaces in architectural satin finish. All welded construction. Secured to cabinet with tumbler lock keyed like other Bradley units. Front of cabinet has matching curvature to other Bradley Diplomat washroom accessories.

Capacity

Waste Container - 12 gal. (1.6 cu. ft.)

Optional large capacity container - 18 gal. (2.5 cu. ft.)

Operation

Receptacle removable for servicing by unlocking waste container. Operates with less than 5 lbs. of force.

Installation

Verify all rough-in dimensions prior to installation. Recessed unit requires rough wall opening 15³/₄"W x 29³/₁₆"H x 4"D. Secure to framing with mounting screws (not included) at holes provided. Shim at screw points as required.

Guide Specification

[12 gal./1.6 cu. ft.] [18 gal./2.5 cu. ft.] capacity waste receptacle in [recessed] [semi-recessed] [surface-mounted] wall cabinet with self-trimming flange. Waste receptacle face formed with contemporary contours, radii, and finish matching related accessories in manufacturer's designer series. Waste receptacle removable from cabinet with keyed tumbler lock. Universal keying. Formed from stainless steel sheet with satin finish on exposed surfaces, fully welded, with seamless corners and burr-free edges: cabinet and flange 0.036-inch/20-ga. thick, waste receptacle 0.036-inch/20ga. thick.

Overall dimensions: 17¹/₈"W x 30⁵/₈"H x 8¹¹/₁₆"D.

Orders composed of products indicated as **Bradex**[®] will be available to ship in three days after receipt of order at the factory. There is no pricing penalty for this service from Bradley.

Page 1 of 2
12/19/2012
This information is subject to change without notice.
Bradley_WasteReceptacle_3A05

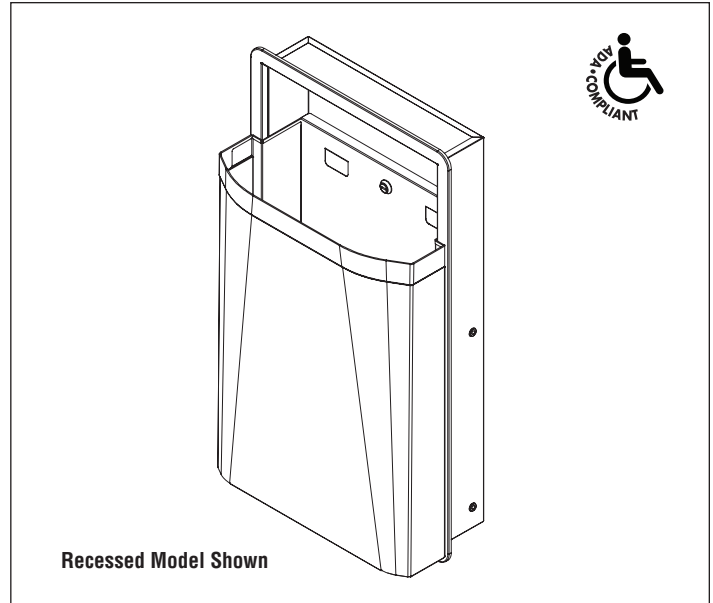

Recessed Model Shown

MasterFormat Title: Commercial Toilet Accessories

MasterFormat Number: 10 28 13.13

OmniClass Title: Toilet and Bath Specialties

OmniClass Code: 23.31.25.00

Optional:

Feature	Suffix
<input type="checkbox"/> Large Capacity Waste Container: 18 gal.	-36
<input type="checkbox"/> 12 Gallon Vinyl Liner Part #P11-044	
<input type="checkbox"/> 18 Gallon Vinyl Liner Part #P11-041	

ADA Compliant

- Consult local and national accessibility codes for proper installation guidelines.
- Conformity and compliance to local and national codes is the responsibility of the installer.

For information on Warranties, Maintenance and BAA/ARRA Compliance, visit our web site at: bradleycorp.com/products/accessories/.

© 2015 Bradley
P.O. Box 309, Menomonee Falls, WI 53052-0309
800 BRADLEY (800 272 3539) +1 262 251 6000
bradleycorp.com



Dimensions

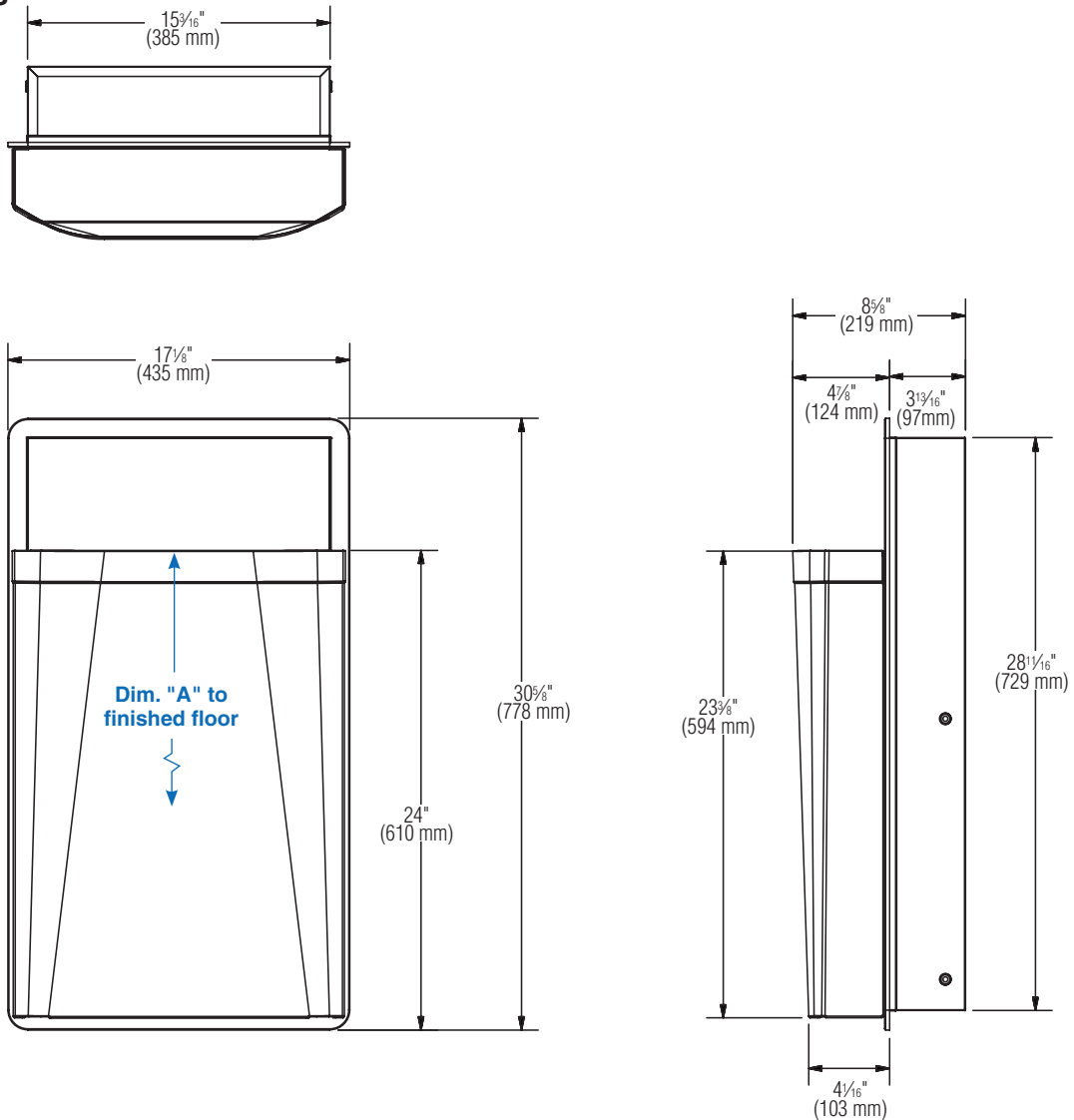

Recessed Model Shown

Dim. "A" Key Surface:	For Dim. "A"	Locate Top of Unit	Locate Bottom of Unit
Waste receptacle top lip to finished floor	36" (914mm)	41 3/4" (1060mm)	12 5/8" (321mm)
	32" (813mm)	37 3/4" (959mm)	8 5/8" (219mm)
	28" (711mm)	33 3/4" (857mm)	4 5/8" (117mm)

Orders composed of products indicated as **Bradex**® will be available to ship in three days after receipt of order at the factory. There is no pricing penalty for this service from Bradley.

Page 2 of 2
 12/19/2012
 This information is subject to change without notice.
 Bradley_WasteReceptacle_3A05

© 2015 Bradley
 P.O. Box 309, Menomonee Falls, WI 53052-0309
 800 BRADLEY (800 272 3539) +1 262 251 6000
 bradleycorp.com