

SureFlo® Automatic, Counter-Mounted Soap Dispenser

INSTRUCTIONS FOR INSTALLATION, OPERATION & MAINTENANCE

BOBRICK MODEL B-824 LIQUID SOAP DISPENSER

Clearances and Mounting Requirements:

- 1-3/8" (35mm) diameter mounting hole required.
- Minimum 18" (457mm) vertical clearance needed below the counter.
- 5" (127mm) diameter clearance needed below the mounting hole to accommodate bottle and bottom housing.
- Minimum 2-1/4" (57mm) diameter clearance needed for Mounting nut directly below the counter to clear sink rim.
- Recommend drilling mounting hole 6" to 8" (152 to 203mm) from the wall, and 2-1/2" to 3" (64 to 76mm) from sink rim.



Scan For SureFlo Installation and Maintenance Instructions.

For New Installation:

- Refer to mounting template for drilling locations (Form No. 824-307).

For Retrofit:

1. Remove existing dispenser(s).
2. Clean area.
3. Ensure hole is 1-3/8" (35mm) diameter.
4. If necessary, enlarge opening using appropriate hole saw. For granite/marble counters, recommend using a diamond hole saw (consult with stone and granite specialist). If needed, mounting hole should be offset to clear the sink rim. The Mounting Nut requires 2-1/4" (57mm) diameter clearance directly below the counter.

Unit Diagram:

Item	Description
1	Top Assembly with Spout, Door and Stem
2	LED Light Pipe
3	Liquid Nozzle Tip
4	Fiber Optic Insert with Sensor Lenses
5	Rubber Counter Gasket
6	Wave Washer
7	Mounting Nut
8	Stem Mounting Nut
9	Duckbill Housing
10	Bottom Housing Assembly (includes Soap Bottle)
11	Battery Pack (requires (4) "D" cell alkaline batteries not included)
12	(3) Fiber Optic Cables for Sensor and LED Light Pipe
13	Fiber Optic Connector Tip Assembly
14	Fiber Optic Nut
15	Portion Control Knob
16	Automatic System Flush Button
17	Key Hole
18	BobKey
19	Optional: A/C Adapter Kit with U.S. Plug, Order Part No. 3974-57. International AC Adapter Plug Kit (UK, Europe Australia) 3974-55

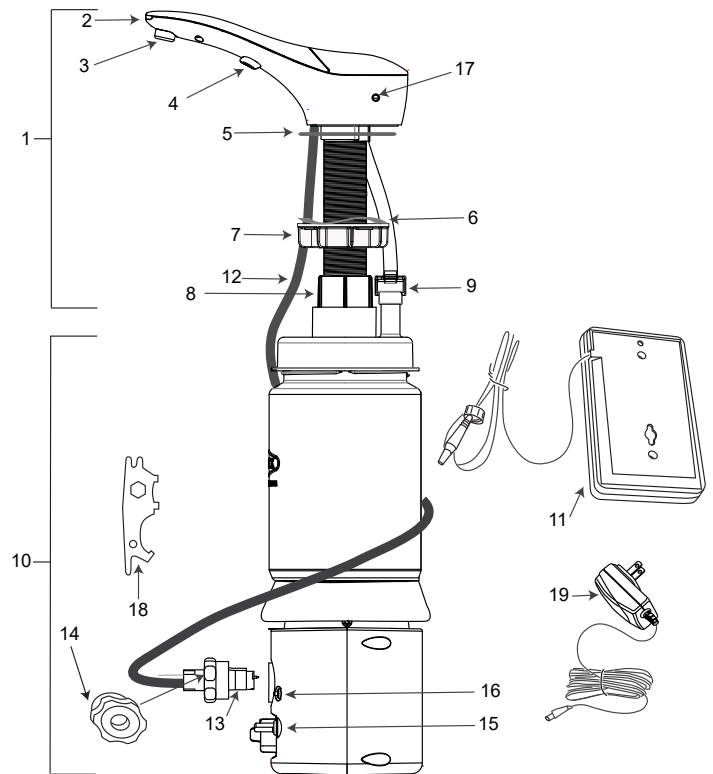

Installation:



1. Place Counter Gasket over mounting hole to align with profile of dispenser.



2. Insert Stem with tube and all Fiber Optic Cables carefully through mounting hole.



3. Place the Wave Washer on top of the Mounting Nut. Install Mounting Nut on Stem and thread upwards. (Minimum 2-1/4" (57mm) diameter clearance needed below mounting nut).

NOTE: The outer diameter of the Mounting Nut may need to be dremeled down if space under the counter is tight.

NOTE: Make sure Fiber Optic Cables and Tubing are **INSIDE** Mounting Nut. Do not tighten completely until end of installation.



4. Thread the Stem Locking Nut onto the Stem. The ribs on the Nut are to be towards the top. Once it goes past the two red o-rings, the nut will automatically stop threading.



5. Attach the tubing to the top barb of the Duckbill Housing.



6. The Bottle Cap can only be placed onto the Stem in one orientation.

The flat section on the Stem is to be aligned with the flat section on the Bottle Cap.



7. Rotate the Bottle back and forth to align the flat section of the Stem to the flat section on the Bottle.



8. Push the Bottle Assembly up onto the Stem while also inserting the Duckbill Housing into the hole in the post on the Bottle Cap.

Fully insert the Bottle Assembly over the Stem until it stops. Both red o-rings must be inside the Bottle Cap.



Replacement Parts List

Part Name

- A/C Adapter
- International AC Adapter Plug Kit (U. K., Europe, Australia)
- Mack Gasket Kit
(To secure Top Assembly under the counter due to irregular counter surface)
- External A/C Multi Adapter Kit
- Nozzle Tip Replacement Kit Liquid
- D Size Battery Pack (Batteries not included)
- Duckbill Housing
- Installation Hardware Packet
(Includes Wave Washer, Counter Gasket, Mounting Nut, BobKey, Stem Mounting Nut)
- Top Housing Assembly Liquid
(Includes Installation Hardware Packet and Duckbill Housing)
- Bottom Housing Assembly Liquid

Part No.

- 3974-57
- 3974-55
- 824-167
- 824-201
- 824-210
- 824-241
- 824-322
- 824-443
- 824-525
- 824-550



9. While pushing upwards on the Bottle, Thread the Stem Locking Nut down onto the Bottle Cap threads

NOTE: After assembly, hold the Stem and lightly rotate the Bottle back and forth and tug down to be sure it is on tight. If it is loose, repeat Steps 7 and 8.

NOTE: Tug Tubing on Duckbill Housing down from under the counter to straighten out the tubing.



10. Insert Fiber Optic Connector Tip into Bottom Housing. Keyed feature on Connector Tip ensures Fiber Optic Cables are always located correctly.



11. Thread Fiber Optic Nut onto Connector Port and hand snug only. Do not over-tighten.



12. Align the Top Assembly above the counter to the desired position and tighten the Mounting Nut against the bottom of counter so the Top Assembly does not easily rotate. Make sure Fiber Optic Cables are not between the underside of the counter and top of Mounting Nut. See Steps 3 and 4.

Apply a bead of Silicone around the base of the Top Housing to prevent spilled soap from going through the mounting hole.



13. Mount Battery Pack on wall nearest dispenser. Mounting hardware is inside the Battery Pack.

*Round Cap on plug is not required for this model, pull back prior to plugging into port.

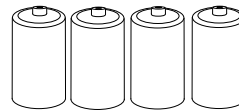

14. Install 4 "D" cell Alkaline batteries.



15. Plug Power Supply into Bottom Housing base.

TOP FILL ONLY !

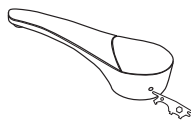

Filling Instructions: (use liquid soap only)

Unit will dispense Bulk Liquid Soap within a viscosity range of 100 to 19,000 cP.

1. Insert tip of BobKey provided into opening of concealed locking mechanism to disengage door.
2. Door will disengage and rotate clockwise for filling from the top.
3. Fill dispenser with commercially marketed bulk liquid hand soap (**Do not use foam liquid**).
4. Close door counter-clockwise to lock in place.

To Operate:

1. **Prime Unit** – After filling dispenser, plug in power to start prime. If unit is plugged in prior to filling dispenser, place hand under spout within sensor location to start prime.



2. **Standard Dispense** – Place hand under spout within the sensor location for approximately 1/2 second to dispense controlled amount of liquid hand soap.

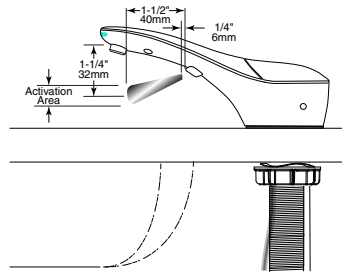

3. **Adjusting amount of soap dispensed** – Depending on viscosity of liquid soap used, unit may dispense between 0.4 ml to 3 ml of soap. To reduce output of liquid soap, rotate Portion Control Knob counter-clockwise. To increase the output of liquid soap, turn the knob clockwise.



4. **LED Light Indicators** – When activated, solid green LED will light. If green light is flashing, remove hand to allow unit to reset, then activate again. Flashing red LED light indicates time to replace batteries.

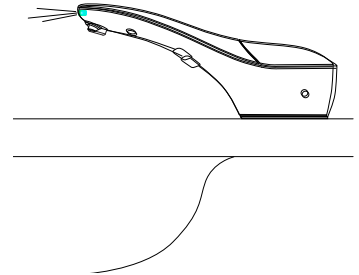

Routine Cleaning and Maintenance:

Using a damp cloth, wipe the chrome-plated exterior of the dispenser daily. Periodically (about 3 to 6 months), it is recommended to flush the system with lukewarm water for cleaning and maintenance.

1. When minimal amount of soap is left in the bottle, fill dispenser with lukewarm water from top to dilute soap.
2. Press the Automatic System Flush Button to flush the system.
3. Once unit is flushed, press the Automatic System Flush Button again to stop dispensing.
4. Fill unit with fresh soap and dispense as usual.



Troubleshooting:

1. Soap dispenser does not dispense soap, but you can hear motor running. The green LED lights up when hands are under spout.
 - a. Press the Automatic System Flush Button until soap comes out
 - b. Press the Automatic System Flush Button again to turn it off
2. Soap dispenser does not dispense soap and you cannot hear motor running. The green LED does not light up when hands are under spout.
 - a. Be sure power is supplied to unit.
 - b. Make sure Fiber Optic Nut is tight on Fiber Optic Port.

Warranty:

SureFlo Automatic Liquid Soap Dispenser is warranted to be free from defects in workmanship and material under normal usage from the date of purchase for a period of 3 years.



© 2020 by Bobrick Washroom Equipment, Inc.
Form No. 824-391 r7/22/20 Printed in U.S.A.

In the United States: **BOBRICK WASHROOM EQUIPMENT, INC.**
New York: 200 Commerce Drive, Clifton Park, NY 12065-1350 • Tel: (518) 877-7444 • Fax: (518)-877-5029
Los Angeles: 6901 Tujunga Ave, North Hollywood, CA 91605-6213 • Tel: (818) 982-9600 • Fax: (818)-503-9287
or email customerservice@bobrick.com

In Canada: **BOBRICK WASHROOM EQUIPMENT COMPANY**
45 Rolark Drive, Scarborough, Ontario M1R 3B1 • Eastern Canada: Tel: (877) 423-6555 • Fax: (877) 423-8555
• Western Canada: Tel: (877) 423-6444 • Fax: (877) 423-8444 or email customerservice@bobrick.com

MOUNTING TEMPLATE

LEFT SIDE

RIGHT SIDE

View from Top of Counter

View from Top of Counter

Recommended Mounting Distance
to Finish Face of Wall

Between 6" to 8" (154 to 203mm)

Recommended Mounting Distance
to Finish Face of Wall

Between 6" to 8" (154 to 203mm)

Drill
1-3/8" (35mm)
Diameter Hole

Drill
1-3/8" (35mm)
Diameter Hole

2-1/2" to 3"
(64 to 76mm)
from Sink Rim
to center
of Mounting Hole

2-1/2" to 3"
(64 to 76mm)
from Sink Rim
to center
of Mounting Hole

6"
(152mm)

6"
(152mm)

7"
(178mm)

7"
(178mm)

8"
(203mm)

8"
(203mm)

7"
(178mm)

7"
(178mm)

MOUNTING TEMPLATE

SureFlo® Automatic Counter-Mounted Soap Dispensers (Bobrick Models B-824, B-850, B-852, B-855, B-856, B-858 Liquid)

Required Clearances:

Mounting Hole: 1-3/8" (35mm) diameter

Maximum Counter Thickness: 2" (50mm)

Below Counter:

18" (457mm) vertical clearance

5" (127mm) diameter directly below mounting hole for bottle and bottom housing.

2-1/4" (57mm) diameter needed for mounting nut directly below mounting hole. If sink rim below the counter is within the clearance area, use a spacer to ensure mounting nut is firmly tightened against, bottom of the counter.

Instructions:

- Using template, locate mounting hole position (on left or right side). Ensure sink and plumbing fixtures **DO NOT** interfere with dispenser above or below the counter (refer to clearances).
- Drill 1-3/8" (35mm) diameter hole.

Sinks with Rim Over the Counter Area:

Unit is not compatible with a sink rim greater than the maximum dimensions listed below:

Option A

X = 1-1/2" (38mm) Maximum

Y = 1" (25mm) Maximum

Option B

X = 2-1/2" (63mm) Maximum

Y = 1/2" (12mm) Maximum

CAUTION:

Rim must not come into contact with activation area.

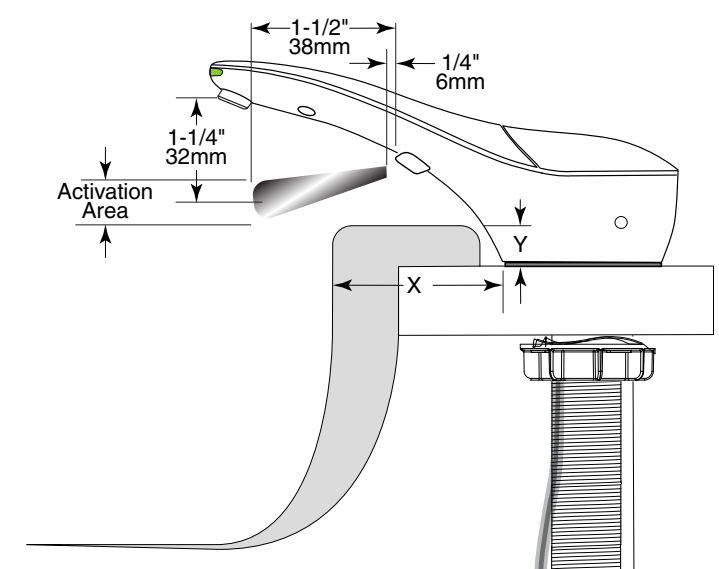
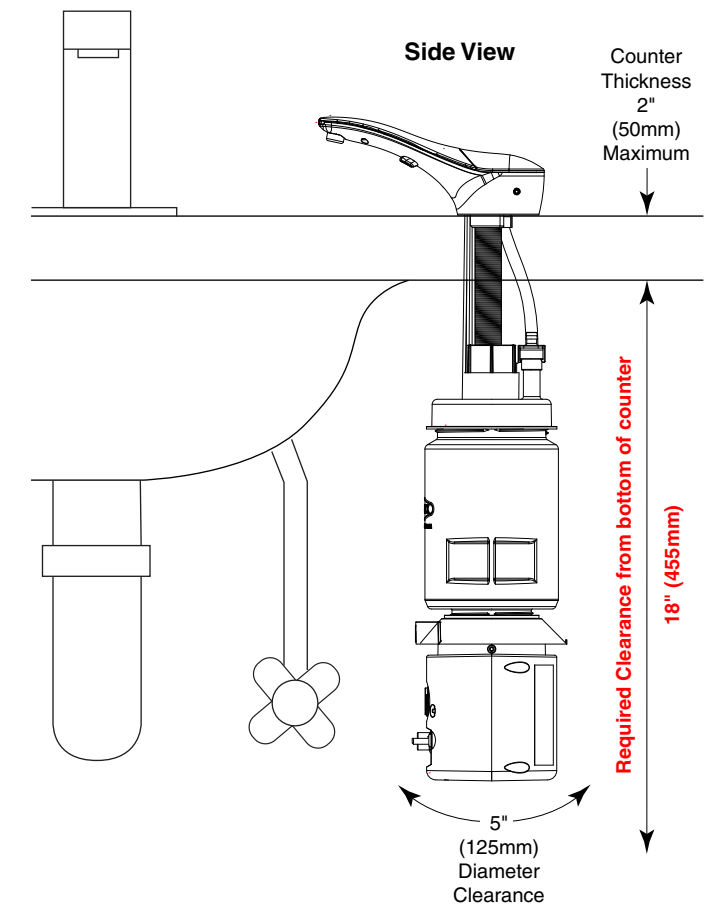

BUILDING VALUE SINCE 1906

In the United States: **BOBRICK WASHROOM EQUIPMENT, INC.**
 New York: 200 Commerce Drive, Clifton Park, NY 12065-1350 • Tel: (518) 877-7444 • Fax: (518)-877-5029
 Los Angeles: 6901 Tujunga Ave, North Hollywood, CA 91605-6213 • Tel: (818) 982-9600 • Fax: (818)-503-9287
 or email customerservice@bobrick.com

In Canada: **BOBRICK WASHROOM EQUIPMENT COMPANY**
 45 Rolark Drive, Scarborough, Ontario M1R 3B1 • Eastern Canada: Tel: (877) 423-6555 • Fax: (877) 423-8555
 • Western Canada: Tel: (877) 423-6444 • Fax: (877) 423-8444 or email customerservice@bobrick.com

© 2019 by Bobrick Washroom Equipment, Inc.
 Form No. 824-307 r8/7/19 Printed in U.S.A.