

# ELKAY® SPECIFICATIONS

## Wall Mount Water Cooler Air Cooled Wall mount Models EWA4, EWA8, EWA14, EWA16, EWA20

**RATED FOR INDOOR USE ONLY**

### GENERAL

Self-contained, electric refrigerated, wall hung water cooler. Capacity of 50°F drinking water, based upon 80°F inlet water and 90°F ambient. Model EWAD(\*) delivers non-refrigerated drinking water. Non-pressurized tank system is standard. Non-pressurized water tank is located after bubbler valve, so that tank is subject to line pressure only when valve button is pressed. Unit shall be lead-free design which is certified to NSF/ANSI 61 and 372 and meets Federal and State low-lead requirements.

### STANDARD FEATURES

- Removable front panel offers easy accessibility to interior
- Extra deep basin minimizes splashing; with integral drain
- Exclusive Flexi-Guard® Safety bubbler
- Cooler Panel Finish options: Impact-resistant vinyl coating or Stainless Steel
- Rated for Indoor use

### COOLING SYSTEM

- Compressor: Hermetically sealed, reciprocating type, single phase. Sealed-in lifetime lubrication.
- Condenser: Fan cooled, copper tube with aluminum fins. Fan motor is permanently lubricated.
- Cooling Unit: Combination tube-tank type. Tube portion is continuous coil of copper tubing. Fully insulated with EPS foam which meets Underwriters Laboratories Inc. Requirements for self extinguishing material.
- Refrigerant Control: Refrigerant R134a is controlled by accurately calibrated capillary tube.
- Temperature Control: Easily accessible enclosed adjustable thermostat is factory preset. Requires no adjustment other than for altitude requirements.



**Warranty:** 5 year limited warranty on the unit's refrigeration system. Electrical components and water system are warranted for 12 months from date of installation or 18 months from factory shipment, whichever date falls first.



### CONSTRUCTION

- Stainless Steel basin with integral drain
- Galvanized structural steel cooler chassis provides structural integrity
- Cooler cabinet available as Light Gray Granite, or Sandalwood Vinyl Clad Steel or Stainless Steel (additional cost) construction
- Exclusive Flexi-Guard® Safety Bubbler utilizes an infused anti-microbial pliable polyester elastomer to prevent accidental mouth injuries. Flexes on impact.
- Cabinet design allows for flush to wall mounting
- † Option for additional Glass Filler (ordered separately)

### CAPACITIES CHART

Model	Voltage / Hertz	Chilling** Capacity	F.L. Amps	Rated Watts	Approx. Ship Wt.	† Glass Filler (option) (F) available at extra cost (order separately) Requires Factory prep to receive glass filler	 UL399 and CAN/CSA 22.2 No. 120 Certified	 ADA COMPLIANT	 NSF/ANSI 61 and 372 Certified
EWA4(*)1Z	115V / 60Hz	4.0 GPH	3.3	230	60 lbs.	YES	•	•	•
EWA4(*)2YJO	220V / 50Hz	3.3 GPH	2.0	230	74 lbs	YES	++	•	•
EWA4(*)3YJO	220V / 60Hz	4.0 GPH	2.0	230	74 lbs.	YES	++	•	•
EWA8(*)1Z	115V / 60Hz	7.6 GPH	5.0	370	72 lbs.	YES	•	•	•
EWA8(*)2YJO	220V / 50Hz	6.3 GPH	2.0	370	74 lbs.	YES	++	•	•
EWA8(*)3YJO	220V / 60Hz	7.6 GPH	2.2	370	74 lbs.	YES	++	•	•
EWA14(*)1Z	115V / 60Hz	13.5 GPH	8.0	665	76 lbs.	YES	•	•	•
EWA14(*)2YJO	220V / 50Hz	11.3 GPH	4.8	665	74 lbs.	YES	++	•	•
EWA14(*)3YJO	220V / 60Hz	13.5 GPH	4.0	665	74 lbs.	YES	++	•	•
EWA16(*)1Z	115V / 60Hz	15.5 GPH	6.5	510	70 lbs.	YES	•	•	•
EWA16(*)2YJO	220V / 50Hz	13 GPH	3.8	510	74 lbs.	YES	++	•	•
EWA16(*)3YJO	220V / 60Hz	15.5 GPH	4.0	510	74 lbs.	YES	++	•	•
EWA20LK1Y	115V / 60Hz	19.5 GPH	8.0	665	74 lbs.	YES	•	•	•
EWA20LFK1Y	115V / 60Hz	19.5 GPH	8.0	665	74 lbs	YES	•	•	•
EWA20SFK1Y	115V / 60Hz	19.5 GPH	8.0	665	74 lbs	YES	•	•	•
EWAD(*)	–	–	–	–	–	YES	•	•	•

\*Color code of (L) Light Gray, (S) Stainless Steel (T) Sandalwood cooler wrapper.

\*\*Based on 80°F inlet water & 90°F ambient air temp for 50°F chilled drinking water

++Complies; not third party certified.

*This specification describes an Elkay product with design, quality and functional benefits to the user. When making a comparison of other producer's offerings, be certain these features are not overlooked.*



**Wall Mount Water Cooler**  
**Air Cooled Wall mount**  
**Models EWA4, EWA8, EWA14, EWA16, EWA20**

**ELKAY®**  
**ROUGH-IN DIMENSIONS**

**RATED FOR INDOOR USE ONLY**

Open space rough-in design permits new installation or replacement of existing fountains and coolers with this Elkay cooler when rough-in is within the outline shown.

**IMPORTANT! INSTALLER PLEASE NOTE:**

This water cooler has been designed and built to provide water to the user which has not been altered by materials in the cooler waterways.

The grounding of electrical equipment such as telephone, computers, etc to water lines is a common procedure. This grounding may be in the building or occur away from the building. This grounding can cause electrical feedback into a water cooler creating an electrolysis which creates a metallic taste or causes an increase in the metal content of the water. This condition is avoidable by installing the cooler using the proper materials as shown below.

**NOTICE**

This water cooler must be connected to the water supply using a dielectric coupling. The cooler is furnished with a non-metallic strainer which meets this requirement. The drain trap, which is provided by the installer, should also be plastic to completely isolate the cooler from the building plumbing system.

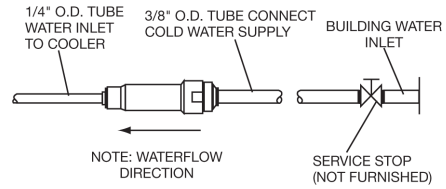

**OPERATION OF QUICK CONNECT FITTINGS**

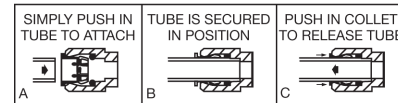

PUSHING TUBE IN BEFORE PULLING IT OUT HELPS TO RELEASE TUBE

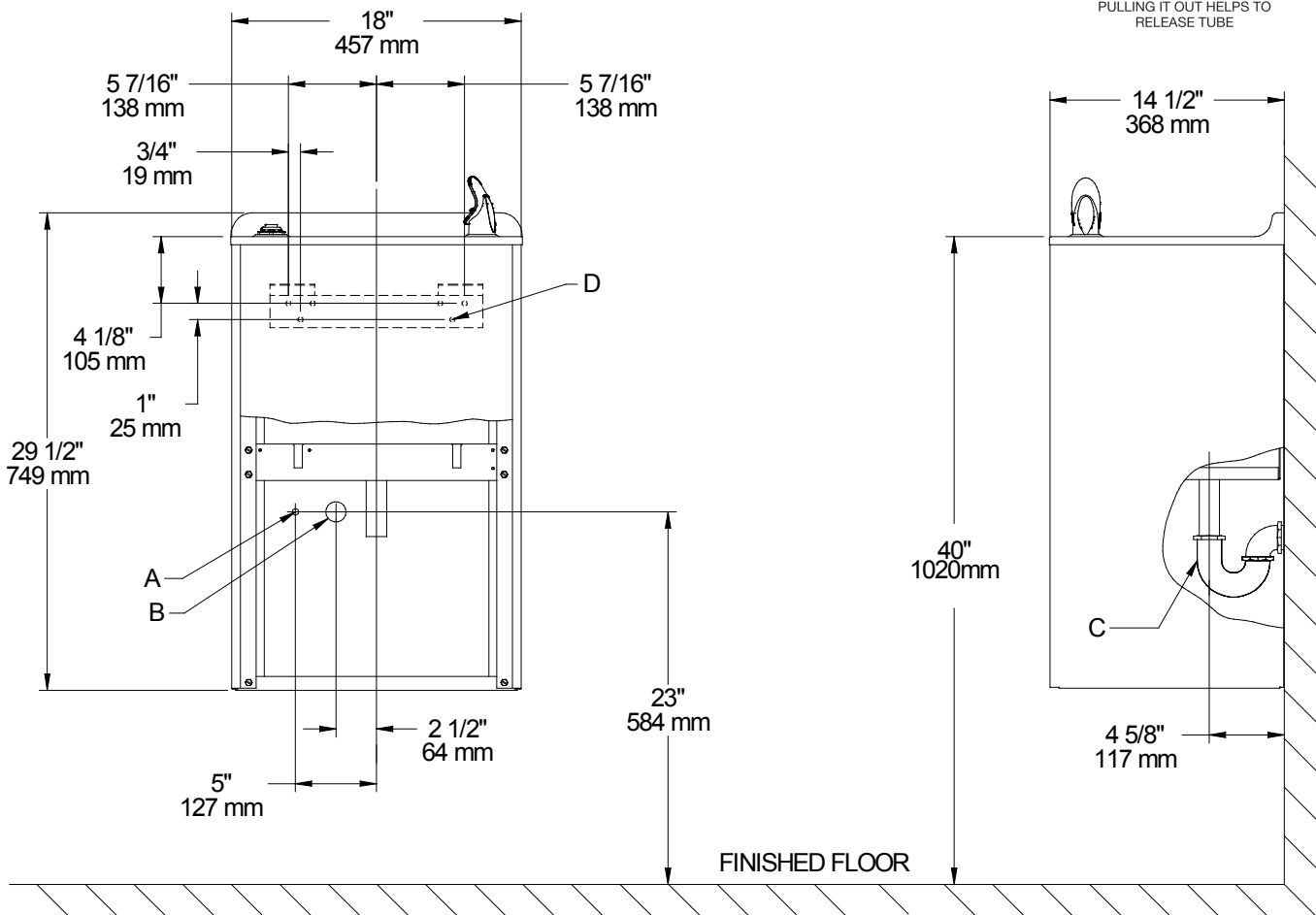

**LEGEND**

- A = RECOMMENDED WATER SUPPLY LOCATION 3/8 O.D. UNPLATED COPPER TUBE CONNECT STUB OUT 1-1/2 IN. (38mm) FROM WALL SHUT OFF BY OTHERS
  - B = RECOMMENDED LOCATION FOR WASTE OUTLET 1-1/4" O.D. DRAIN
  - C = 1-1/4 TRAP NOT FURNISHED
  - D = 5/16" (8mm) SCREW HOLES IN MOUNTING PLATE
- NOTE: New Installations Must Use Ground Fault Circuit Interrupter (GFCI)

Job Name: \_\_\_\_\_  
 Model: \_\_\_\_\_ Qty. \_\_\_\_\_  
 Contact: \_\_\_\_\_  
 Approval Signature: \_\_\_\_\_  
 Notes: \_\_\_\_\_