

FOR INSTALLATION OR SERVICE

ASSISTANCE PLEASE CALL

(734) 421-2400 OR

Email: sales@americandryer.com

IMPORTANT: HAVE MODEL & SERIAL NO. READY

MODEL # _____ SERIAL # _____

WARNING: DISCONNECT POWER BEFORE SERVICING
DESUNA LA ELECTRICIDAD ANTES DE HACER REPARACIONES

INSTALLATION INSTRUCTIONS

1. Remove cover by removing (2) tamper-proof screws using security wrench supplied. Pull cover directly toward you. **IMPORTANT:** Save security wrench.
2. Dryers should be placed at least 2 feet (61cm) apart and at least 12" (30cm) from washbasin. Do not install dryer over washbasin. Automatic dryers should be at least 18" (46cm) above any projection which may interfere with the operation of the automatic sensor.

Hold the backplate to the wall at the suggested **MAXIMUM** mounting height. Measure from bottom edge of **backplate** to the **floor** (Ref. Dimension "A", Fig. 1):

MEN	WOMEN	CHILDREN (depends on age)	DISABLED
44" (112cm)	42" (107cm)	32 to 42" (81-107cm)	36" (91cm)

3. Mark the locations of the four mounting holes and the conduit entrance location on the wall. (The conduit entrance is the proper hole diameter for 1/2 inch (13mm) conduit.)
4. Fasten the backplate to the wall where previously marked.

RECOMMENDATION:

Wood wall – No. 14 (M6) wood screws, 2-3/4" (70mm) long

Cement or brick – 1/4" (M6) stud expansion bolts, 3" (76mm) long

Hollow wall – 1/4" (M6) toggle bolts, length depends on wall thickness

5. Run service wire to the dryer location and connect to lead wires.
IMPORTANT: All units must be supplied with 3 wire service. Use No. 12 or 14 wire as required by local electrical code. The ground wire must be connected to the dryer ground screw. Unit must be installed by a qualified licensed electrician.

GXT - CONNECT EACH DRYER TO A DEDICATED 15 OR 20 AMP LINE.

EXT - CONNECT UP TO THREE DRYERS TO ONE DEDICATED 20 AMP LINE.

Dryers located in shower rooms or other wet locations should be equipped with ground fault interrupter(s).

6. **Carefully** replace the cover using (2) tamper-proof screws supplied. Apply a bead of caulk around edges of cover to wall.

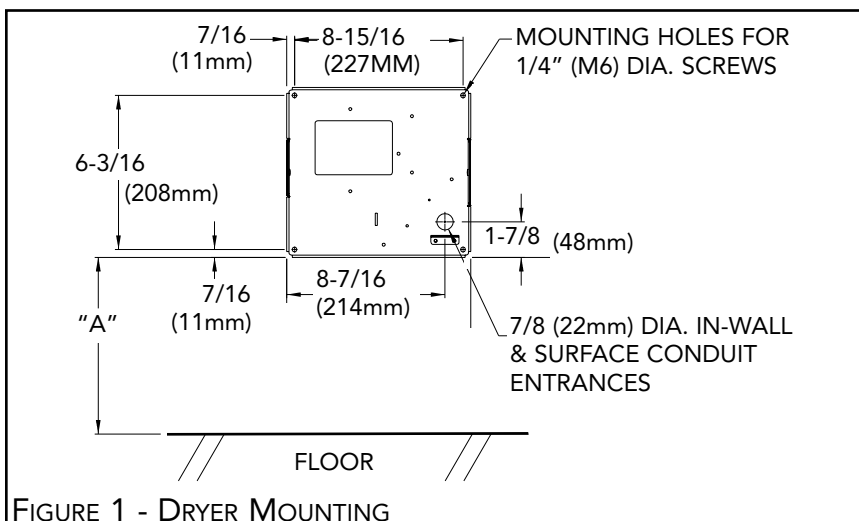

FIGURE 1 - DRYER MOUNTING

EXTREMEAIR LIMITED WARRANTY

All parts of the **EXTREMEAIR** models are warranted to the original consumer purchaser to be free from defects in material and workmanship for a period of five (5) years from the date of purchase from manufacturer. All models outside of the U.S.A., one (1) year including sensor. We will replace **FREE OF CHARGE**, during the warranty period, any warranted part which proves defective in material and/or workmanship under normal installation, use, and service, excluding normal wear. Replacement parts can be obtained by returning the part, **TRANSPORTATION CHARGES PREPAID**. You must notify factory prior to returning part or dryer. Any damage to this dryer as a result of misuse, abuse, neglect, accident, improper installation, unauthorized repairs, or any other use violative of instructions furnished by us, **WILL VOID THIS WARRANTY**. THIS LIMITED WARRANTY IS THE SOLE WARRANTY ON OUR PRODUCTS, AND WE DISCLAIM AND EXCLUDE ANY AND ALL OTHER WARRANTIES, EXPRESS OR IMPLIED, INCLUDING ANY IMPLIED WARRANTIES OF MERCHANTABILITY OR FITNESS FOR A PARTICULAR PURPOSE. OUR LIABILITY SHALL NOT EXCEED IN ANY EVENT THE REPLACEMENT OR SALE PRICE OF THE ALLEGEDLY NONCONFORMING PRODUCT AND SHALL EXCLUDE LABOR CHARGES. TO THE EXTENT PERMITTED BY LAW WE SHALL NOT BE LIABLE FOR ANY LOSS, COST, EXPENSE, OR INCIDENTAL OR CONSEQUENTIAL DAMAGES OF ANY KIND, WHETHER BASED UPON WARRANTY (EXPRESS OR IMPLIED), CONTRACT, NEGLIGENCE OR STRICT LIABILITY AND ARISING IN ANY WAY IN CONNECTION WITH THE DESIGN, MANUFACTURE, SALE, USE OR REPAIR OF THE PRODUCT.

EXTREMEAIR®

MFD by AMERICAN DRYER, INC.

12932 FARMINGTON ROAD, LIVONIA, MI 48150, U.S.A.

Telephone (734) 421-2400 • Fax (734) 421-5580

www.americandryer.com • Email: sales@americandryer.com

Revised November 2010

WARNING: DISCONNECT POWER BEFORE SERVICING
DESUNA LA ELECTRICIDAD ANTES DE HACER REPARACIONES

SERVICE AND MAINTENANCE OF YOUR DRYER

GENERAL OPERATION

This dryer is activated by an infrared sensor. The dryer operates as long as hands are below nozzle. There is a maximum 80 second running time with a safety over-ride feature, if hands are not removed. Each component used in your dryer has been designed to provide years of trouble-free service. However, if trouble should develop, it can normally be located by visual examination. Removal or replacement of most parts is simple and can be done without special tools.

IF THE DRYER WON'T TURN ON:

Check electrical service, circuit breaker. Make sure proper voltage is being supplied to the dryer. Check for loose or disconnected terminal to sensor. **INCREASE** sensitivity (FIGURE 3) by inserting a flat-blade screwdriver through the hole and into the pot to **CAREFULLY** turn the adjustment pot located on the sensor **CLOCKWISE 1/3 turn MAX.** If necessary, replace sensor.

IF DRYER WILL NOT SHUT OFF:

Make certain black foam is attached to lens and lens is clean. If damaged, replace. **DECREASE** sensitivity (FIGURE 3) by inserting a flat-blade screwdriver through the hole and into the pot to **CAREFULLY** turn the adjustment pot located on the sensor **COUNTER-CLOCKWISE. 1/3 turn MAX.** If necessary, replace sensor.

GXT ONLY - IF COLD AIR IS COMING FROM THE NOZZLE:

Turn off breaker for 30 seconds to reset thermostat. If necessary, inspect heating element by unfastening blower housing from backplate (3 screws). Remove heating element from blower housing to inspect for damage. Replace if necessary.

IF NO AIR IS COMING FROM THE NOZZLE:

If the dryer also trips the circuit breaker, replace the motor/blower assembly by unfastening the blower housing from the backplate (3 screws) and remove the inlet shield. Otherwise, replace the sensor.

FOR ANY OTHER PROBLEM, CONTACT FACTORY FOR ASSISTANCE.

CLEANING - DO NOT spray cleaning solvents through dryer vents. DO NOT use abrasive, chlorinated, or highly alkaline cleaners. DO NOT use oil based cleaners.

SEMI-ANNUALLY remove the cover and clean all lint and dust from the mechanism, inside of cover, and plastic window.

Clean cover with a mild soap or detergent and warm water, using a soft cloth or sponge.

PARTS LIST FOR YOUR DRYER (Figure 2)

ITEM	PART NO.	DESCRIPTION
1	GXT202	COVER, WHITE ABS (MUST SPECIFY DRYER MODEL #)
2	GXT202-M	COVER, WHITE STEEL (MUST SPECIFY DRYER MODEL#)
3	GXT202-C	COVER, CHROME PLATED STEEL (SPECIFY DRYER MODEL #)
4	GXT212	NOZZLE ASS'Y W/LENS AND FOAM GASKET
5	GXT216	MOTOR/BLOWER, 110-120V
6	GXT217	MOTOR/BLOWER, 208-240V
7	GXT218	HEATING ELEMENT ASS'Y 110-120V (GXT6-M/C)
8	GXT220	HEATING ELEMENT ASS'Y 208-240V (GXT8-M/C)
9	GX239	SENSOR COMPLETE, 110-240 VOLT
10	GB232	TAMPER-PROOF SCREWS & SECURITY WRENCH

